

Maintenance of Conductor Rails

Program 0800

Contents

1	General information	2
2	Safety regulations	2
2.1	Safety and hazard information.....	3
3	Tools and materials.....	3
4	Maintenance schedule	3
4.1	Current collectors	4
4.1.1	Program 0811 Technical data and test values	5
4.1.2	Program 0812 Technical data and test values	6
4.1.3	Program 0813 Technical data and test values	7
4.1.4	Program 0815 Technical data and test values	8
4.1.5	Program 0831 Technical data and test values	9
4.1.6	Program 0842 Technical data and test values	10
4.2	Conductor rails	10
4.3	Rail connectors.....	11
4.4	Anchor clamps.....	11
4.5	Hanger clamps	12
4.6	Power feeds.....	12
4.7	End caps.....	12
4.8	Pick-up guides for transfer points / Air gap insulating sections	13
4.9	Expansion units	13
4.10	Cleaning	13
4.11	Electrical inspection.....	14
5	Commissioning after maintenance.....	14

Maintenance of Conductor Rails

Program 0800

1 General information

These regulations apply to insulated conductor rails from the programs of the 0800 series (0811, 0812, 0813, 0815, 0831, 0842) with rated voltages up to 1000 V and current ratings of 10 A to 2000 A.

Regular and sufficient maintenance is necessary for the designated functioning of the conductor rail. This prevents a jeopardizing of the operating reliability and of the contact safety guard and is the prerequisite for the eligibility of warranty claims. Under certain circumstances, an additional interim maintenance may be necessary.

2 Safety regulations

The safety regulations detailed in the relevant specification documents are applicable as well as the country-specific regulations for working on electrical devices/systems (e.g. VDE/UVV/VBG4).

Applicable are those safety regulations issued by the particular systems operator with regards to entering the facilities and working on the systems.

Maintenance and repair to the conductor rail must only be performed by appropriately trained expert personnel in accord with the respective technical standards, regulations and laws.

Maintenance and repairs on the electrical system of the device must only be performed by qualified electricians in accord with the respective electrical standards (e.g. VDE, IEC) and country-specific regulations and laws.

Conductor rails are part of the electrical system and must therefore be regularly and repeatedly checked in accordance with the accident prevention regulations (e.g. VBG4).

Only genuine Conductix-Wampfler spare parts must be used. When using other components, Conductix-Wampfler is unable to assume any responsibility whatsoever for the perfect and hazard-free functioning of the system(s) in question.

Maintenance of Conductor Rails

Program 0800

2.1 Safety and hazard information



DANGER!

Danger of injury by electric shock!

- Prior to inspection, maintenance or repair on the conductor rail, the system must be disconnected from the main power supply and secured against unauthorized, accidental and/or improper reactivation.
- If, in special situations, there is no main switch, the disconnection from the power supply is to be handled according to specifications.
- The parts that have been disconnected must first be checked to ensure they are not carrying current, next grounded, and finally short-circuited. Isolate neighboring parts that are carrying current!
- Before each start-up, an insulation check must be performed in accordance with the local technical standards, specifications and laws.
- If a conductor rail heater is present, it must also be disconnected from the power supply. Care must be taken to ensure that each individual heater circuit is disconnected from the power supply.



Danger of crushing between stationary and moving parts of the device!

- Before an inspection, maintenance or repair on the conductor rail, the system must be switched off using the main switch!



Health hazard from carbon dust!

- During maintenance tasks, dust deposits can be stirred up and inhaled.
- A protective dust mask is to be worn!

3 Tools and materials

Standard tools (metric) and measuring tools are used for maintenance on conductor rails. A **caliper** is needed to measure the conductor contact height.

4 Maintenance schedule



A maintenance schedule is recommended in order to regulate the carrying out of maintenance and inspections. Maintenance is carried out by Conductix-Wampfler service personnel or authorized local service partners from Conductix-Wampfler. The advantages of a maintenance contract include increased availability of the system and an economical as well as precise performing of maintenance by trained personnel.

Maintenance of Conductor Rails

Program 0800

4.1 Current collectors

Inspection and maintenance tasks	Maintenance interval	Reference to documents
<p>Visual inspection of the conductor contact for wear and signs of denting, in particular the brushing surfaces,</p> <p>Replace worn conductor contact if the minimum wear level (h_{min})* has been reached at least on one part of the running surface.</p> <p>If there is heaving denting, check whether the connection cables are laid so they are free of twists, kinks and directive force. Also ensure there is adequate clearance for movement of the current collector heads. The individual connection cables must not be bundled together near the current collector heads (e.g. using cable ties).</p>	<p>For new systems, every 500 km or 1 month after commissioning at the latest.</p> <p>For copper graphite collector shoes, the mileage can total up to 8,000 km and for graphite coals (pure coals) up to 20.000 km.</p> <p>Note: Depending on the usage conditions and condition of the unit, the mileage can differ from the above values.</p> <p>The maintenance interval can be broadened depending on experience with the system.</p>	<p>Refer to system-specific documentation.</p>
<p>Check that electrical connection is proper and correct.</p> <p>Visual inspection of the connection cables: Kinks, damages to the insulation or the braiding, cabling, connectors, screw connections, cross-sections of the braiding on the screw terminals of the current collector heads.</p>		
<p>Check installation and lateral tolerance* of the current collector to the conductor rail (except for 0842 line).</p> <p>For optimum operation, the nominal position is recommended for the installation distance. Installation and lateral tolerances must not be exceeded or undershot during operation.</p>	<p>½ annually</p>	<p>Refer to system-specific documentation.</p>
<p>Check the connector elements (screws, rivets, nuts, bolts), ease of movement of the joints and moving parts, corrosion, and damage.</p> <p>Replace if necessary.</p> <p>Check screw connections and tighten if necessary.</p>	<p>½ annually</p>	

* For wear levels, lift/lateral tolerances and contact pressures for standard current collectors, see following table.

Please note: When using special current collectors, other values may be applicable.

Maintenance of Conductor Rails

Program 0800

4.1.1 Program 0811 Technical data and test values

Current collector	Conductor contact length	Wear height		Installation distance			Lateral tolerance	
	L [mm]	h_{max} [mm]	h_{min} [mm]	Nominal position X [mm]	Highest position (stroke +) X [mm]	Lowest position (stroke -) X [mm]	Y [mm]	
081101...	40	5	0.5	50	70	30	16	
081101...	63				105	45		30
081102...	63			75	85	65	10	
081106...	40							
081106...	63							

Illustration of conductor contact length and wear height

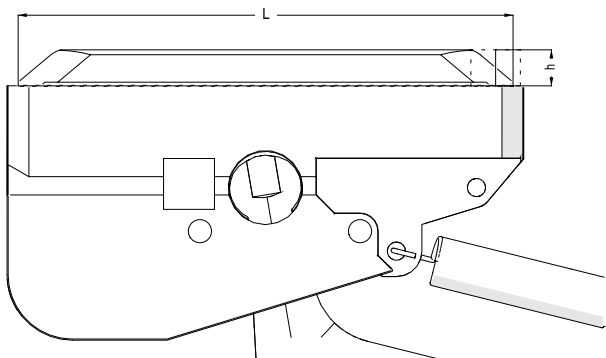

Illustration of the installation distance 081101 and 081102

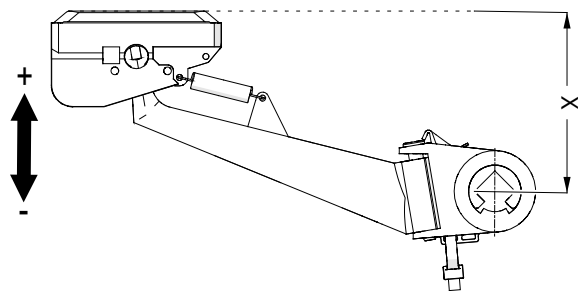

Illustration of the installation distance 081106

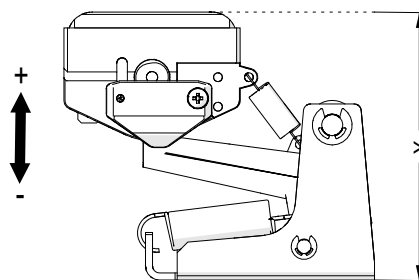
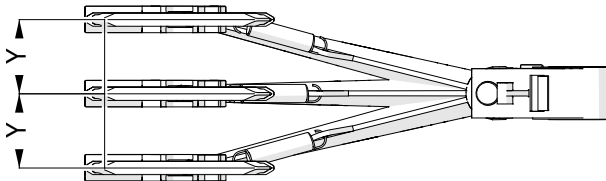

Illustration of the lateral tolerance



Maintenance of Conductor Rails
Program 0800

4.1.2 Program 0812 Technical data and test values

Current collector	Conductor contact length	Wear height		Installation distance			Lateral tolerance
	L [mm]	h_{max} [mm]	h_{min} [mm]	Nominal position X [mm]	Highest position (stroke +) X [mm]	Lowest position (stroke -) X [mm]	Y [mm]
081205...	90	9	0.5	115	165	65	50
081206...							
081207...							
081208...							
081209 1)	80	8					

1) Also **ProShell**-Current collector No. 08-S265-2258 / 08-S265-2259 / 08-S265-2226 / 08-S265-2237 / 08-S265-2403 / 08-S265-2408.

Illustration of conductor contact length and wear height 081205, 081206, 081207, 081208

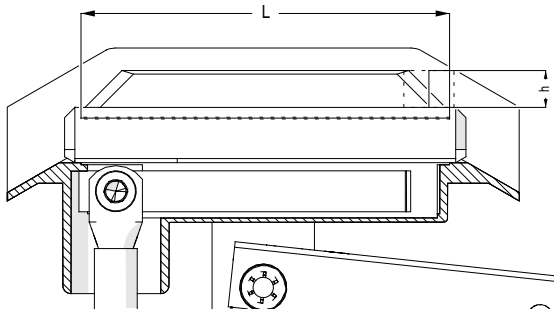

Illustration of conductor contact length and wear height 081209

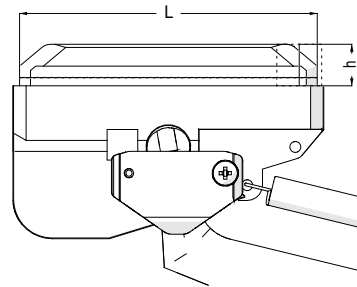

Illustration of the installation distance

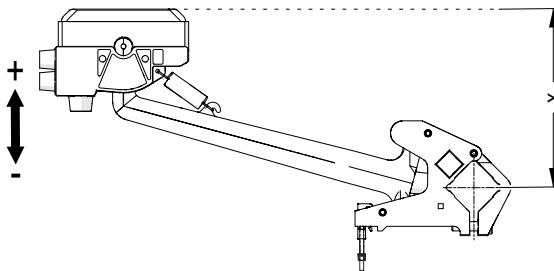
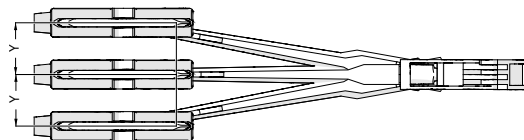

Illustration of the lateral tolerance



Maintenance of Conductor Rails
Program 0800

4.1.3 Program 0813 Technical data and test values

Current collector	Conductor contact length	Wear height		Installation distance			Lateral tolerance
	L [mm]	h_{max} [mm]	h_{min} [mm]	Nominal position X [mm]	Highest position (stroke +) X [mm]	Lowest position (stroke -) X [mm]	Y [mm]
081301...	160	15	0.5	125	165	85	100
081302...		10		100	140	60	40
081303...		15		125	165	85	100
081304...							

Illustration of conductor contact length and wear height

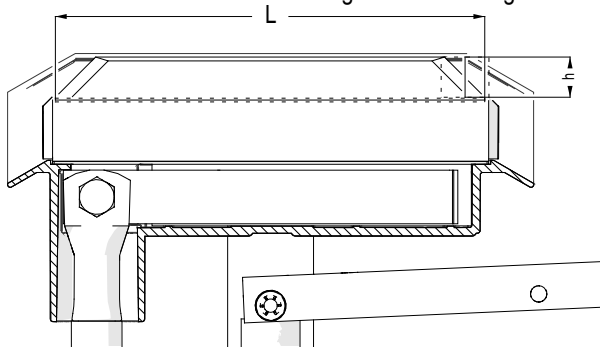

Illustration of the installation distance

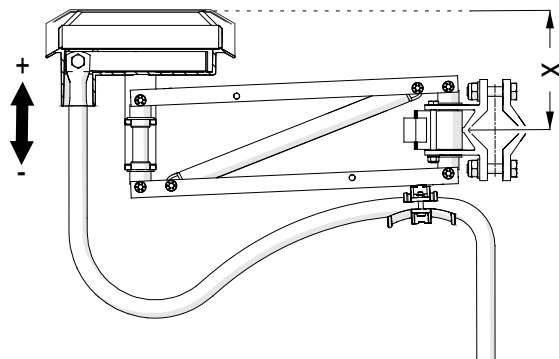
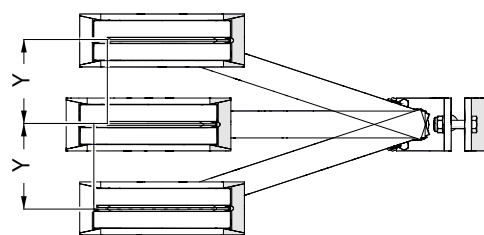

Illustration of the lateral tolerance



Maintenance of Conductor Rails

Program 0800

4.1.4 Program 0815 Technical data and test values

Current collector	Conductor contact length	Wear height		Installation distance			Lateral tolerance
	L [mm]	h_{max} [mm]	h_{min} [mm]	Nominal position X [mm]	Highest position (stroke +) X [mm]	Lowest position (stroke -) X [mm]	Y [mm]
081506...	63	5	0.5	65	75	55	10
081507...							
081508...	50			80	90	70	
081509...							

Illustration of conductor contact length and wear height 081506, 081507

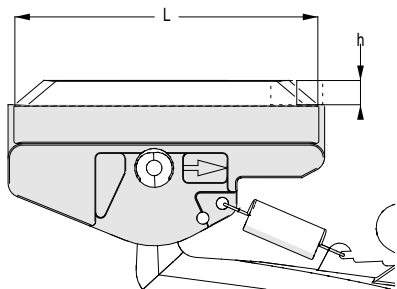

Illustration of conductor contact length and wear height 081508, 081509

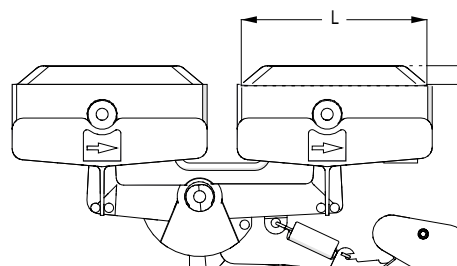

Illustration of the installation distance

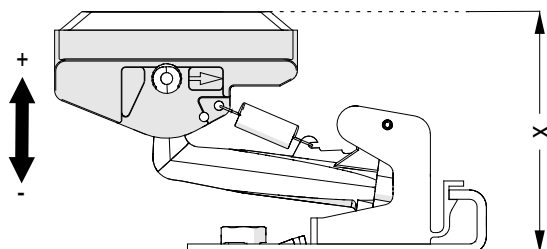
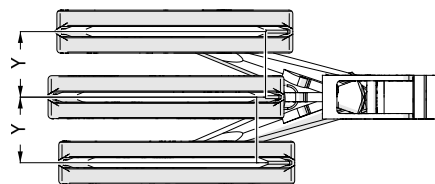

Illustration of the lateral tolerance



Maintenance of Conductor Rails

Program 0800

4.1.5 Program 0831 Technical data and test values

Current collector	Conductor contact length	Wear height		Installation distance			Lateral tolerance
	L [mm]	h_{max} [mm]	h_{min} [mm]	Nominal position X [mm]	Highest position (stroke +) X [mm]	Lowest position (stroke -) X [mm]	Y [mm]
083102...	68	10	5	80	110	50	30
083103...							
083104...							
083106...	80	8	0.5	100	150	50	50
083107...							

Illustration of conductor contact length and wear height 083102, 083103, 083104

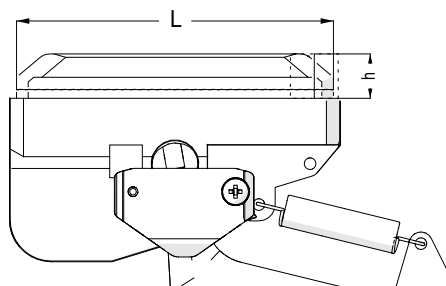

Illustration of conductor contact length and wear height 083106, 083107

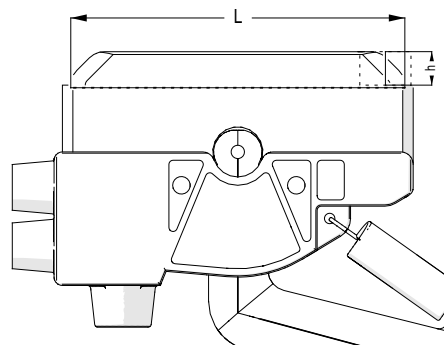

Illustration of the installation distance

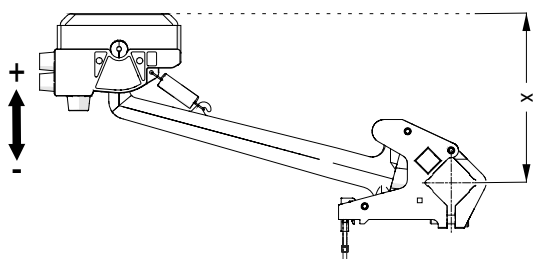
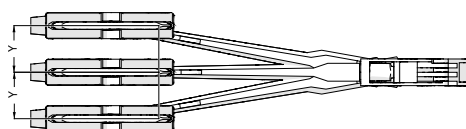

Illustration of the lateral tolerance



Maintenance of Conductor Rails

Program 0800

4.1.6 Program 0842 Technical data and test values

Current collector	Conductor contact length	Wear height	
	L [mm]	h _{max} [mm]	h _{min} [mm]
084201...	25	5	0
084203...	28		

Illustration of conductor contact length and wear height 084201

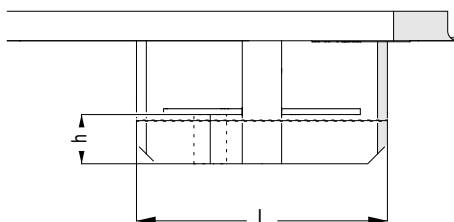
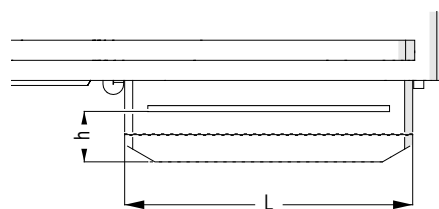

Illustration of conductor contact length and wear height 084203



4.2 Conductor rails

Inspection and maintenance tasks	Maintenance interval	Reference to documents
<p>Visual inspection of the brush surfaces for wear, damage, filth or burn spots. Replace rails if necessary.</p> <p>Ensure that the sliding surfaces are completely burr-free. Particularly on the junctions of the rails, burrs can result in increased carbon wear.</p> <p>Dirty sliding surfaces can be mechanically removed using a cleaning brush. Consult your local service partner for information on cleaning brushes.</p>	½ annually	
<p>Visual inspection of the insulation for wear, damage, filth or burn spots. Replace rails if necessary.</p> <p>Ensure that there are no constrictions in the insulation profile (e.g. constrictions due to dirt in the rails or constrictions that were not removed after assembly and still remain), on which the current collector heads get stuck and can get stood upright (cause for contact problems). Manually check free movement of the rails with loose current collectors.</p> <p>Ensure that the insulation is not affected by foreign bodies (chippings, liquids, dirt, etc.) as this poses a short circuit hazard. Clean if necessary</p>	½ annually	WV0800-0001-E Cleaning conductor rails

Maintenance of Conductor Rails Program 0800

4.3 Rail connectors

Inspection and maintenance tasks	Maintenance interval	Reference to documents
Visual check for damages, dirt, burn spots or corrosion. Replace if necessary. Check for proper electrical connection. Check position of connector caps. Check screw connections and tighten if necessary. Clean if necessary	½ annually	

4.4 Anchor clamps

Inspection and maintenance tasks	Maintenance interval	Reference to documents
Visual check for damages, cracking, dirt, or corrosion. Replace if necessary. Check whether the fixing of the conductor rail is ensured. Check screw connections and tighten if necessary. Check that there are no constrictions in the rails near the anchor clamps. Check free movement with current collectors (see chapter "Conductor rail"). Clean if necessary	½ annually	

Maintenance of Conductor Rails

Program 0800

4.5 Hanger clamps

Inspection and maintenance tasks	Maintenance interval	Reference to documents
<p>Visual check for damages, cracking, dirt, or corrosion. Replace if necessary.</p> <p>Check screw connections and tighten if necessary.</p> <p>Check that there are no constrictions in the rails near the hanger clamps. Check free movement with current collectors (see chapter "Conductor rail").</p> <p>For outdoor systems: Check whether damage (tears, cracks, etc.) has resulted due to weathering (UV radiation, storms, hail, snow, etc.). Replace affected component if necessary.</p> <p>Clean if necessary</p>	<p>½ annually</p>	

4.6 Power feeds

Inspection and maintenance tasks	Maintenance interval	Reference to documents
<p>Visual check for wear, damage, dirt, burn spots or corrosion. Replace if necessary.</p> <p>Check that electrical connection is proper and correct. Visual inspection of the connection cables: kinks, damage to the insulation or braiding, cable routing, connector/screw connections).</p> <p>Check screw connections and tighten if necessary.</p> <p>Clean if necessary</p>	<p>½ annually</p>	

4.7 End caps

Inspection and maintenance tasks	Maintenance interval	Reference to documents
<p>Visual check for wear, damage, dirt, burn spots or corrosion. Replace if necessary.</p> <p>Check screw connections and tighten if necessary.</p> <p>Clean if necessary</p>	<p>½ annually</p>	

Maintenance of Conductor Rails

Program 0800

4.8 Pick-up guides for transfer points / Air gap insulating sections

Inspection and maintenance tasks	Maintenance interval	Reference to documents
<p>Visual check for wear, damage, dirt, burn spots or corrosion. Replace if necessary.</p> <p>Check the crossing tolerances (current collector relative to the pick-up guide/crossing cap). Check the orientation to the conductor rail and to the conductor rail. Note: All current collectors in the system have to be adjusted to each pick-up guide/crossing cap (tolerance 1:n).</p> <p>For several of the pick-up guides that are used by a vehicle, it can be necessary to face the pick-up guides to each other.</p> <p>In general, check the stability of the pick-up guide! Check screw and rivet joints, and tighten/replace as necessary.</p> <p>Clean if necessary</p>	monthly	See system-specific documentation for tolerance

4.9 Expansion units

Inspection and maintenance tasks	Maintenance interval	Reference to documents
<p>Visual check for wear, damage, dirt, burn spots or corrosion. Replace if necessary.</p> <p>Check the stretching gap as depends on temperature</p> <p>Check screw connections and tighten if necessary.</p> <p>Clean if necessary</p>	½ annually	See system-specific documentation for information on stretching gap

4.10 Cleaning

Inspection and maintenance tasks	Maintenance interval	Reference to documents
<p>Cleaning the conductor rail</p> <p>Brush out, vacuum out, and clean with cleaning agents.</p>	As necessary.	WV0800-0001 Cleaning conductor rails

Maintenance of Conductor Rails

Program 0800

4.11 Electrical inspection

Inspection and maintenance tasks	Maintenance interval	Reference to documents
<p>PE conductor: Visual check, free movement check inside the system and on the interfaces, measurement of the grounding resistance.</p> <p>Inspection of the safety guards</p> <p>Measure insulation resistance per phase. See "Reference to documents". Observe additional specifications from system manufacturer!</p> <p>Visual inspection of areas with localized overheating.</p>	After each maintenance	VBG4 Insulation measurements: see WV0800-0001 Cleaning conductor rails

5 Commissioning after maintenance

Before re-commissioning, ensure that...

- all work was completed.
- any possible self-start of machines is prevented.
- the system was inspected, and the personnel was informed.
- the specifications of the system manufacturer were observed.

A test run of the entire system is to be performed.

The system has to be observed during the first hour of operation.